

REPC-Nr.:

Service • Assistenza • Dienstverlening • Serwis  
Servis • Szerviz • Сервисная служба

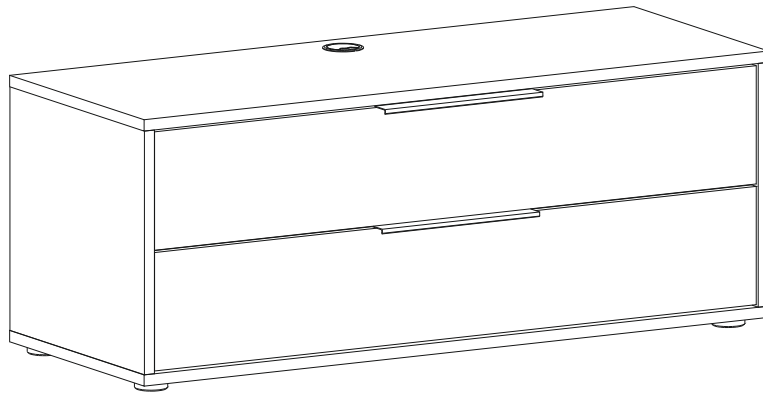

Artikel.-Nr.:

**0624-LB\_011**

Montageanleitung.-Nr.:

**MA1-00179**

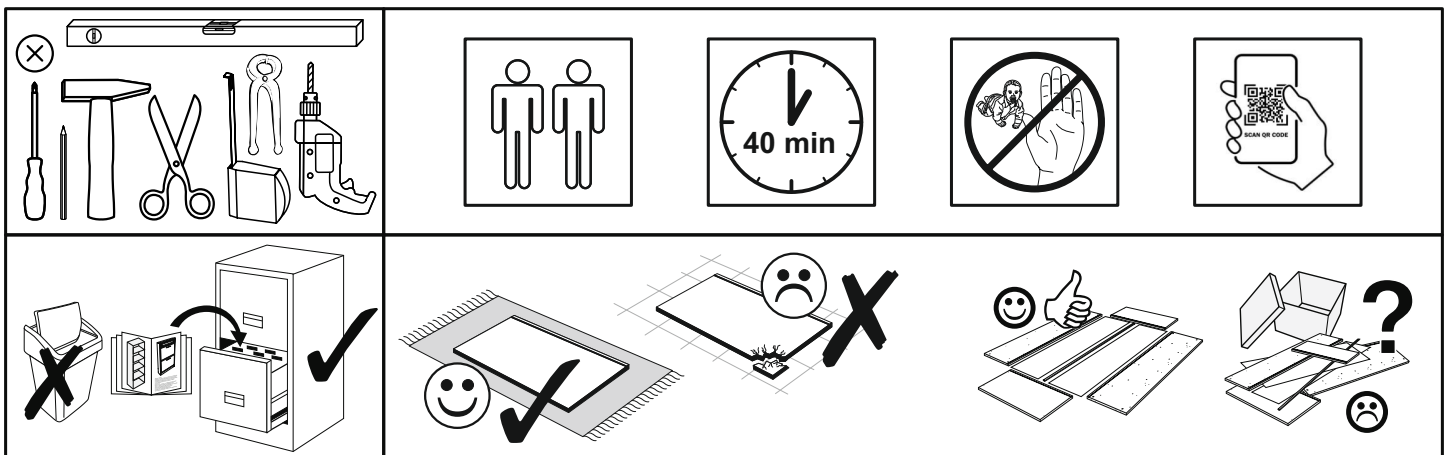

SCAN ME

Das Ersatzteil-Anforderungsformular finden Sie auf  
The replacement parts requisition form you find on  
<https://www.mausbacher.de/ersatzteile/>

## BT1-00432 Colli 1/1

B02-10 14x ø15x12mm	B02-20 14x	B02-103 14x 8x30
B01-90 2x 3,5x20	B01-30 24x 3x16	B01-10 4x 6,3x50
B01-200 10x 6,3x13	B08-40 2x 5,8x65	B08-70 2x ø8mm
B01-122 2x 4,0x13	B01-80 2x 3,5x13	B05-20 4x ø20mm
B01-244 1x		

## BT1-00434 Colli 1/1

B06-423sg 2x 300x15x22	B05-199 1x	B05-190 2x
------------------------------	---------------	---------------

## BT1-00005 Colli 1/1

B02-173 4x	B01-123 8x 4,0x15
---------------	-------------------------

## BT1-00433 Colli 1/1

B03-235 2x	B01-65 13x 3,0x13	B03-225 1x
---------------	-------------------------	---------------



▶ SCAN ME

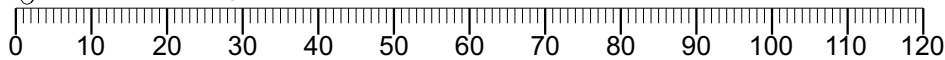
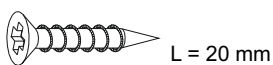

## Colli 1/2

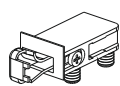

Z08-20  
1x

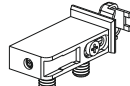

Z08-10  
1x

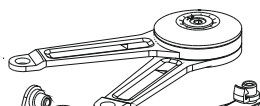

Z07-27  
1x

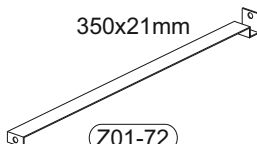

Z01-72  
1x

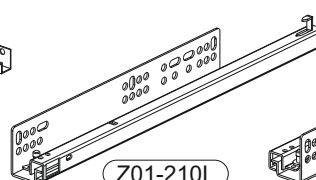

Z01-210L  
1x

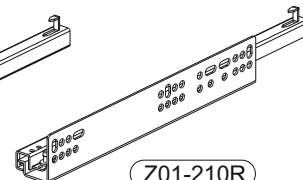

Z01-210R  
1x

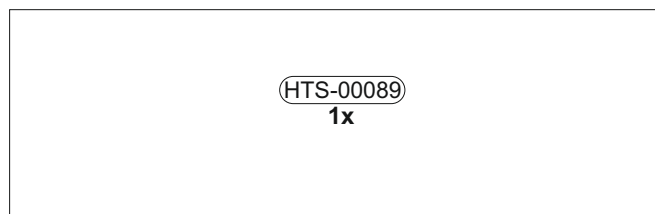

HTS-00089  
1x

1119 x 358

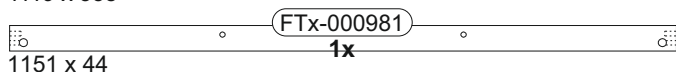

FTx-000981  
1x

1151 x 44

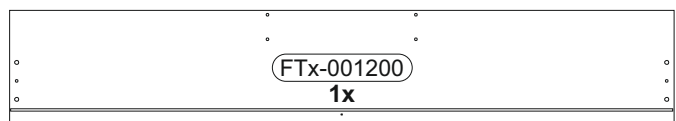

FTx-001200  
1x

1147 x 199

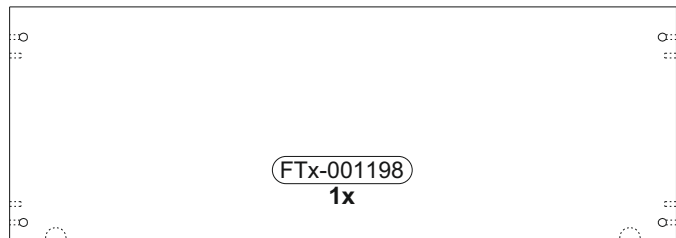

FTx-001198  
1x

1151 x 407

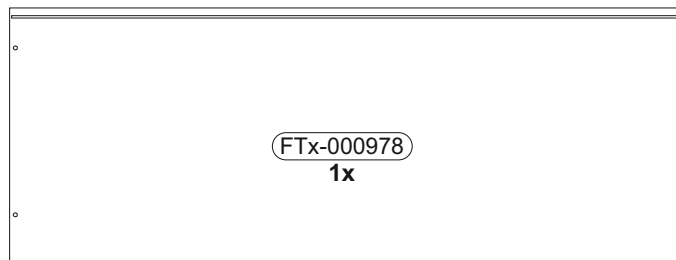

FTx-000978  
1x

1190 x 444

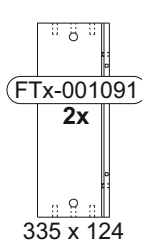

FTx-001091  
2x

335 x 124

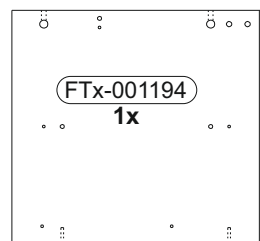

FTx-001194  
1x

410 x 444

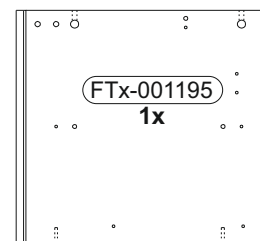

FTx-001195  
1x

410 x 444



FTx-001196  
1x

1138 x 124

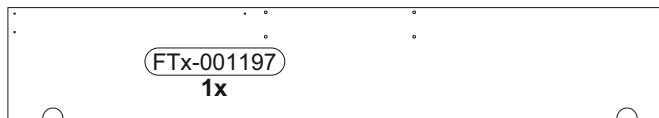

FTx-001197  
1x

1147 x 199



HTR-00513  
1x

1163 x 226

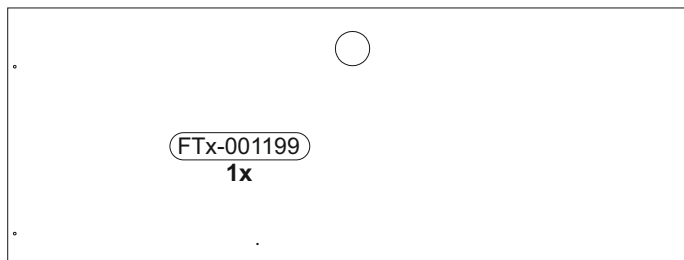

FTx-001199  
1x

1190 x 444

1

	B02-10		B02-20		B01-200	
	4x	ø15x12mm	6x		6x	6,3x13

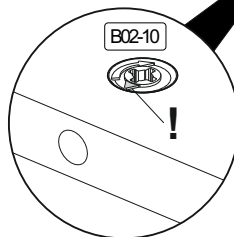
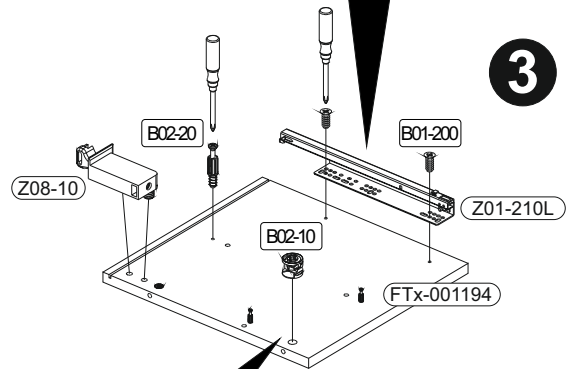
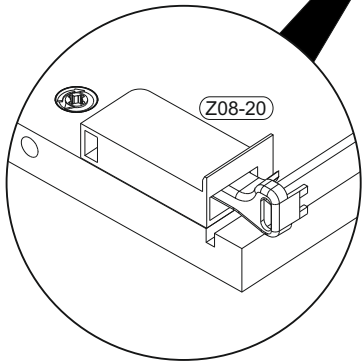
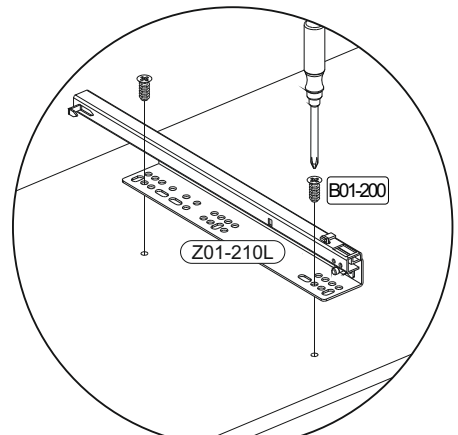
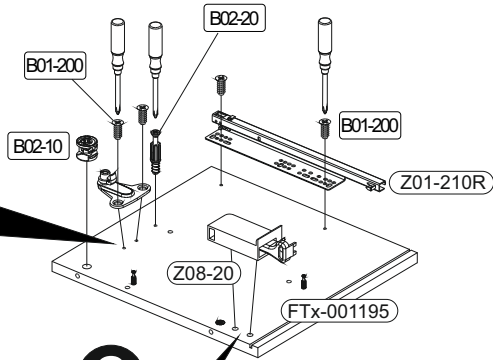
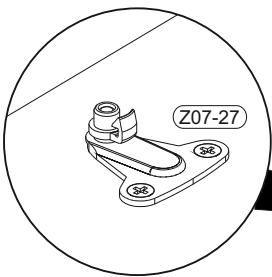
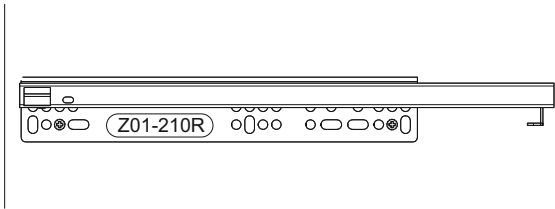
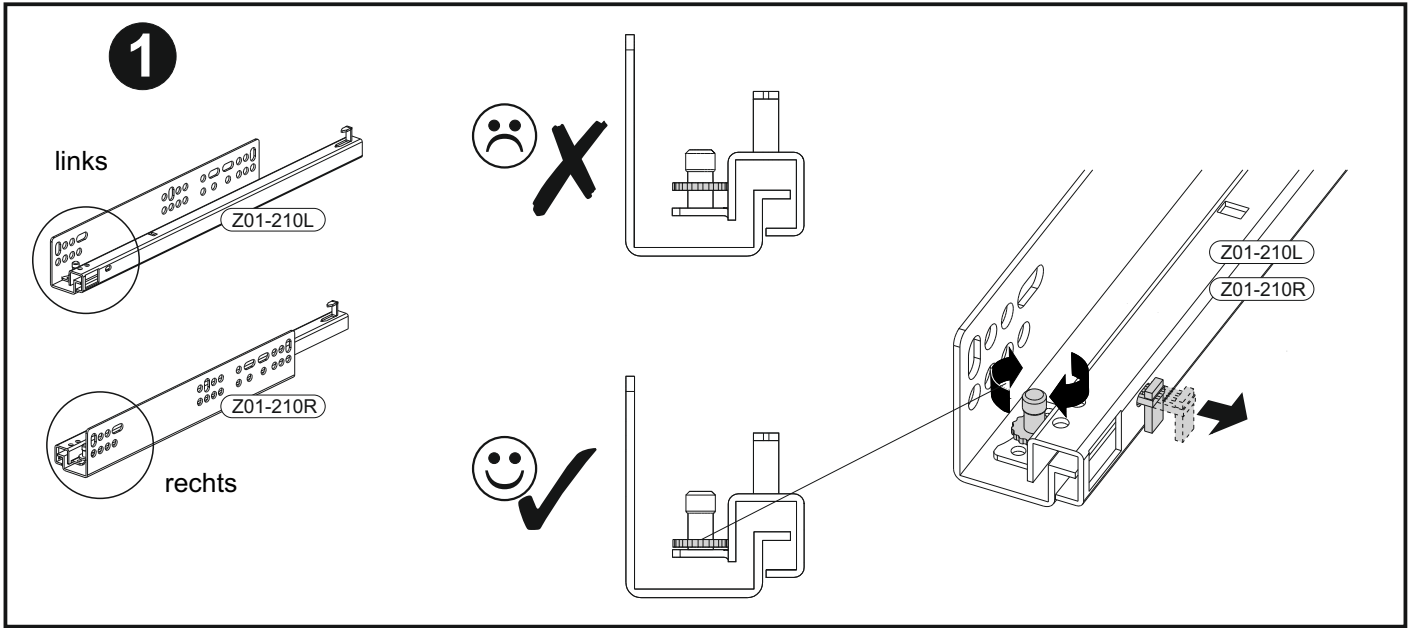

**2**

	B02-20		B01-65		B03-225	
	4x		1x	3,0x13	1x	

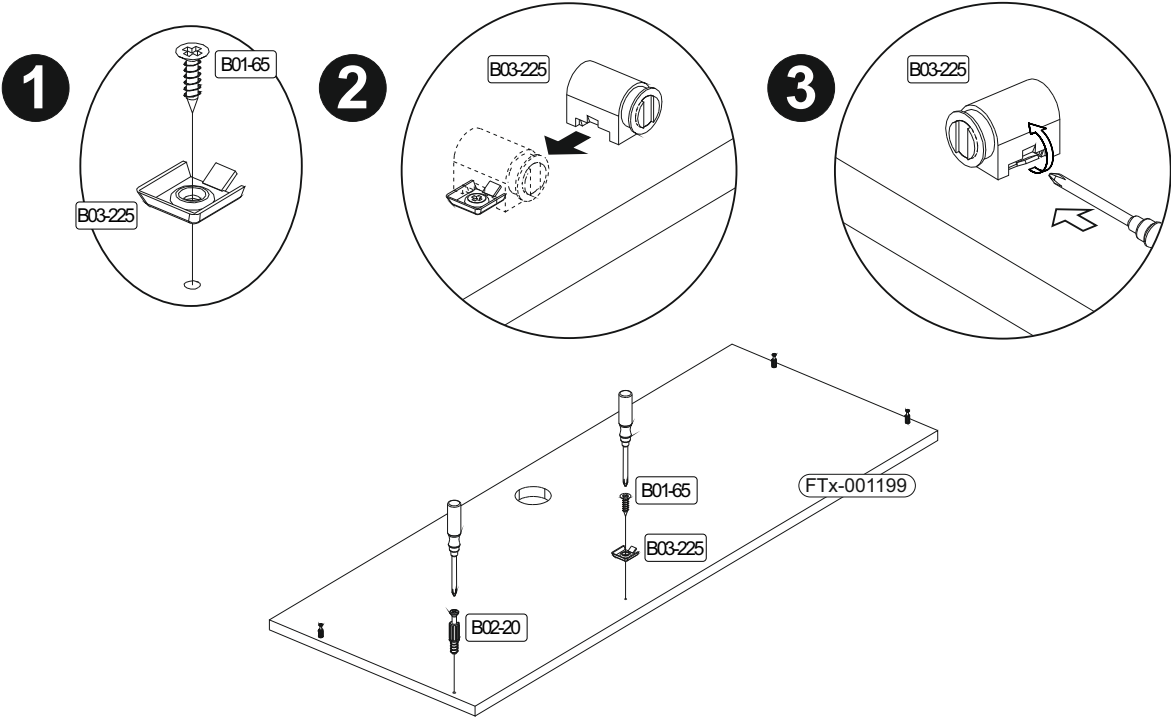

**3**

	B02-10		B05-190		B02-103		B03-235		B01-65	
	6x	ø15x12mm	2x		6x	8x30	2x		6x	3,0x13

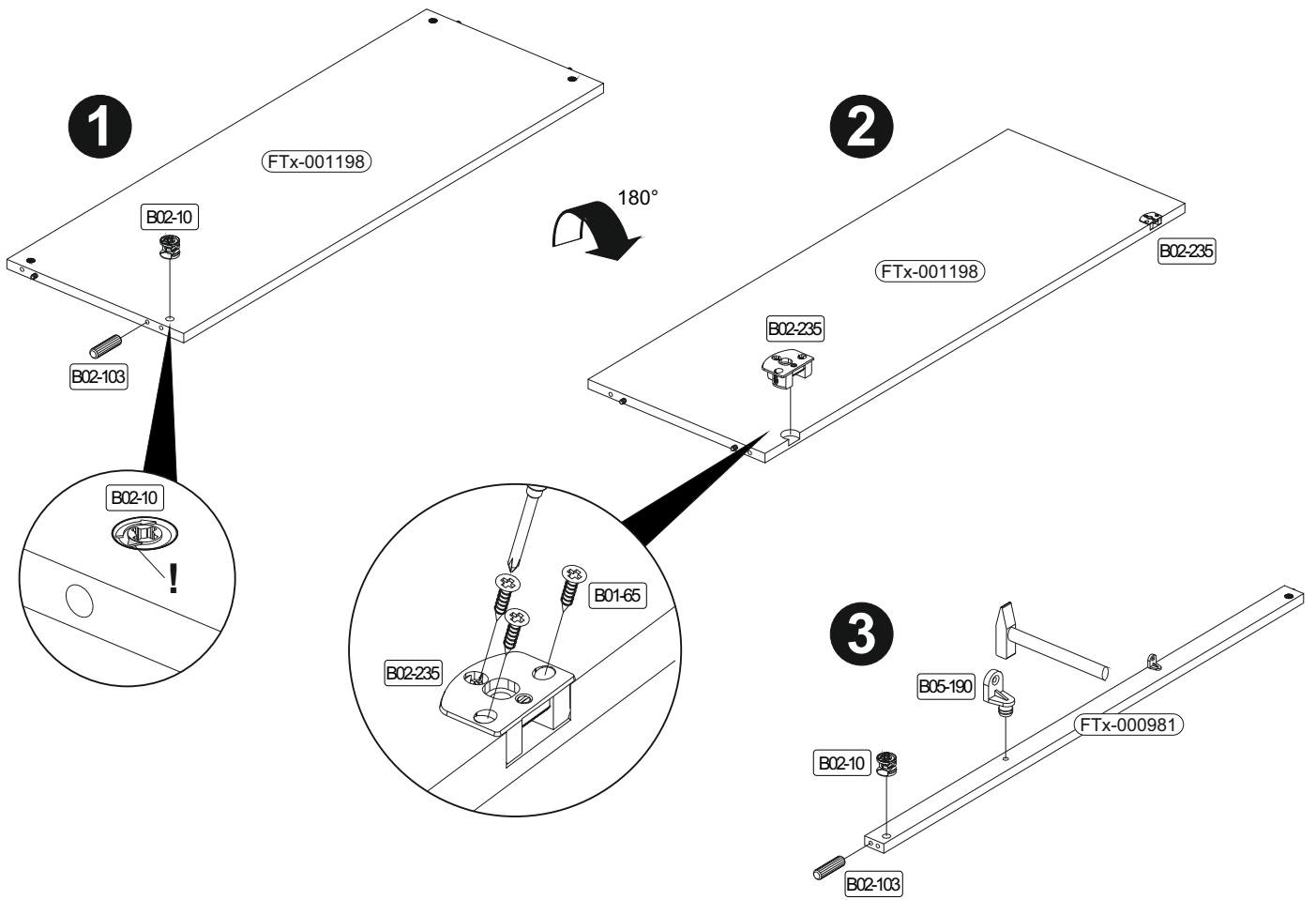

**4**

	B02-10 4x	 ø15x12mm 4x	B02-20 4x	 B02-103 8x	 8x30 2x	B01-122 2x	 4,0x13 12x	B01-30 2x	 3x16 2x	 6,3x13 1x
							 300x15x22 2x	B01-200 2x		

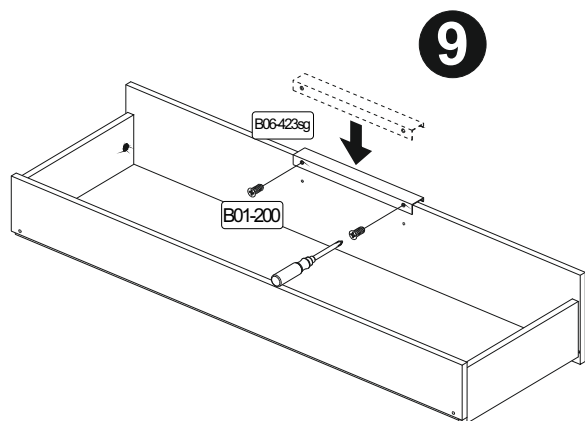
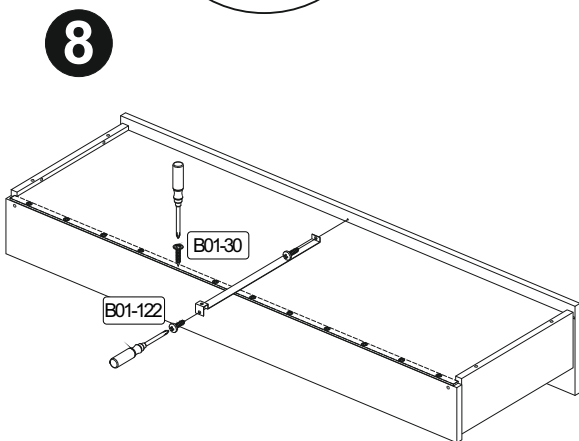
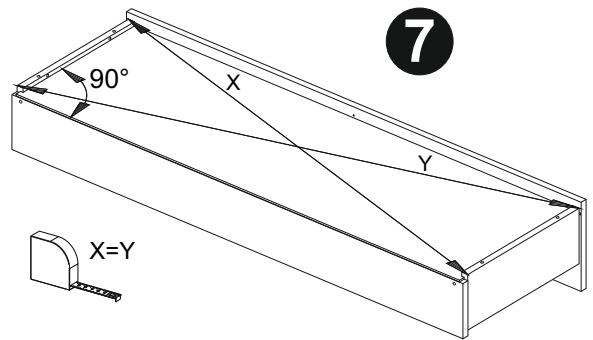
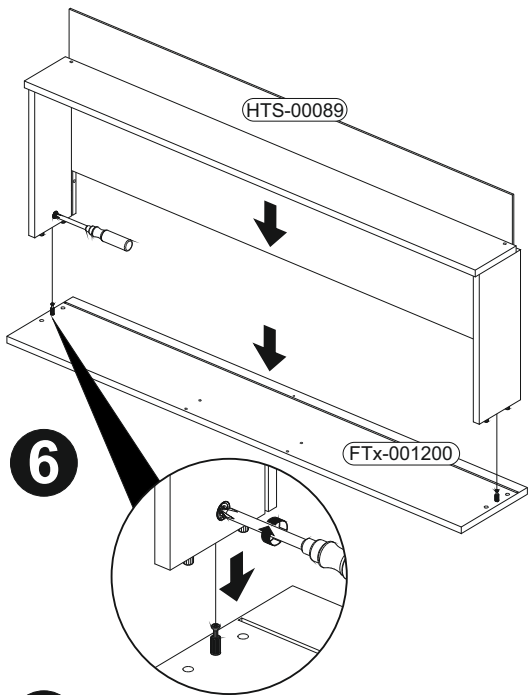
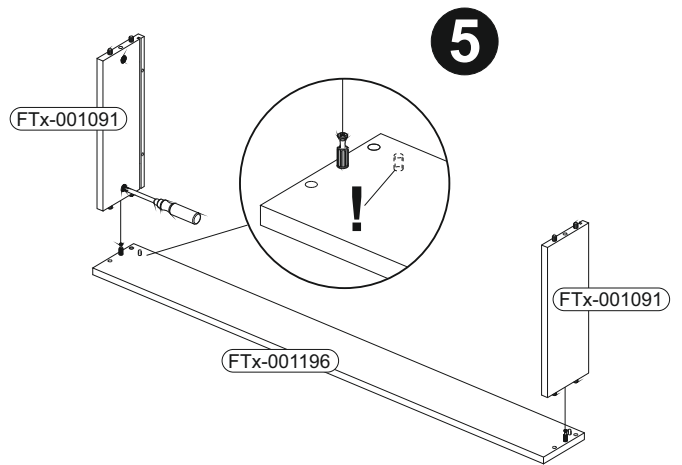
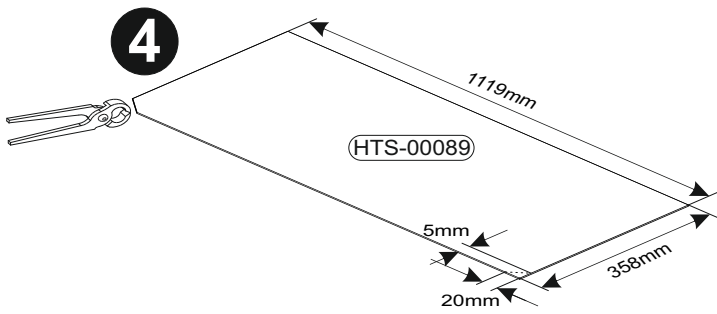
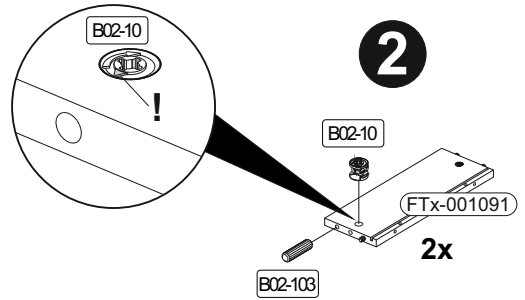
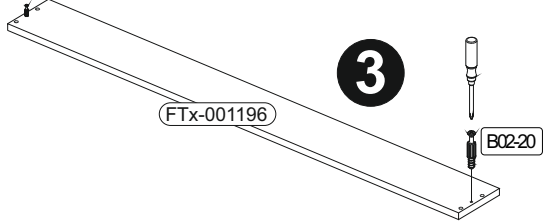
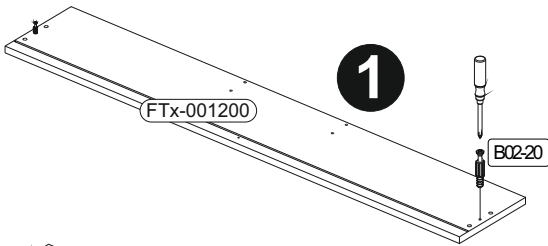

**5**

	B01-10		B01-90		B01-244	
4x	6,3x50	2x	3,5x20	1x		

**1**

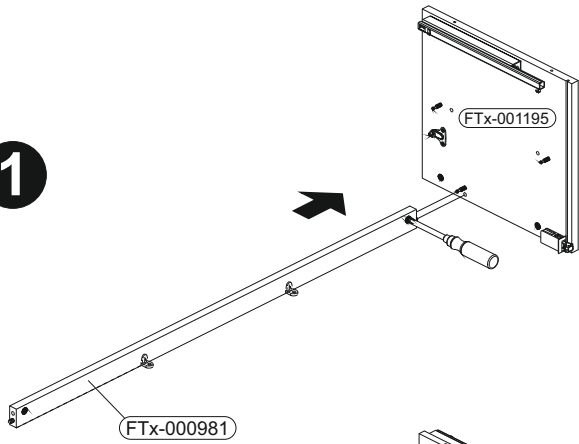

**2**

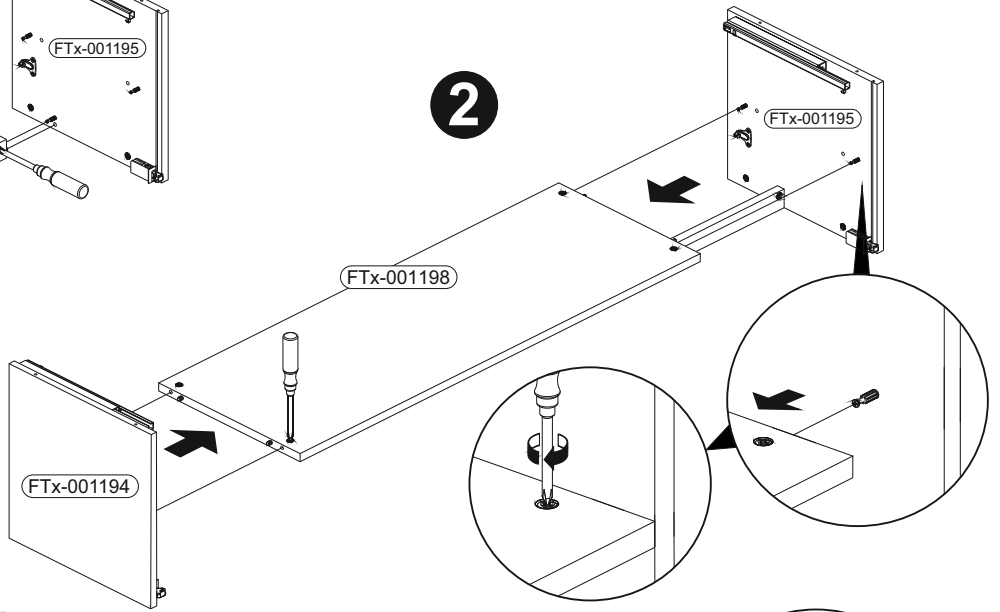



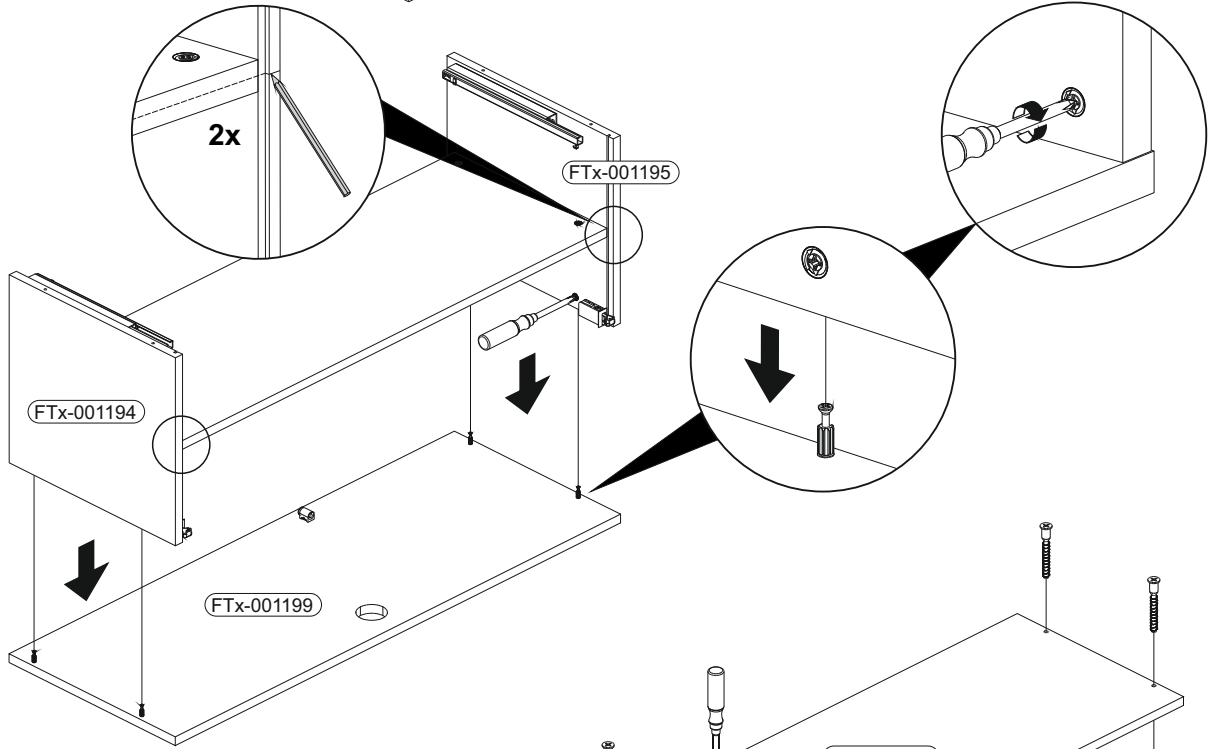

**3**

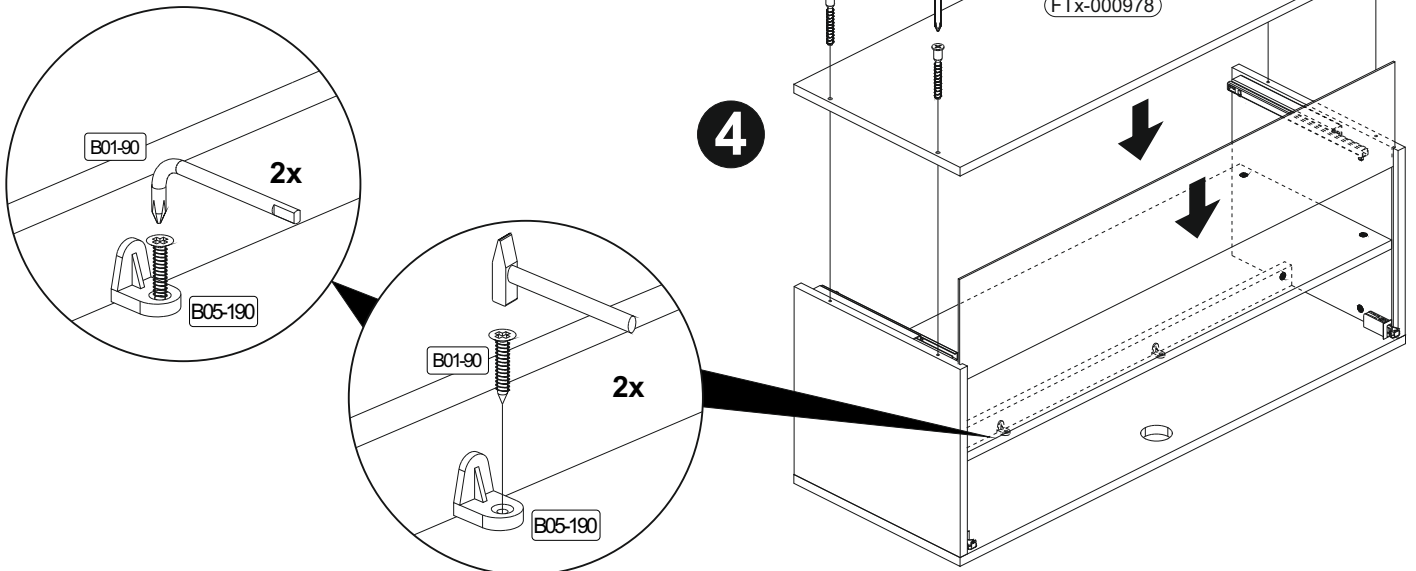

**4**



6

				
	4x	8x	4,0x15	12x
				3x16

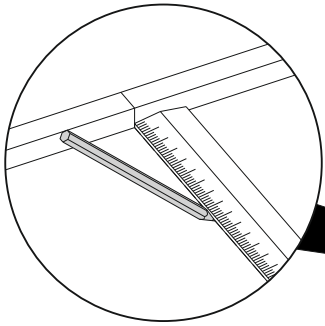

1

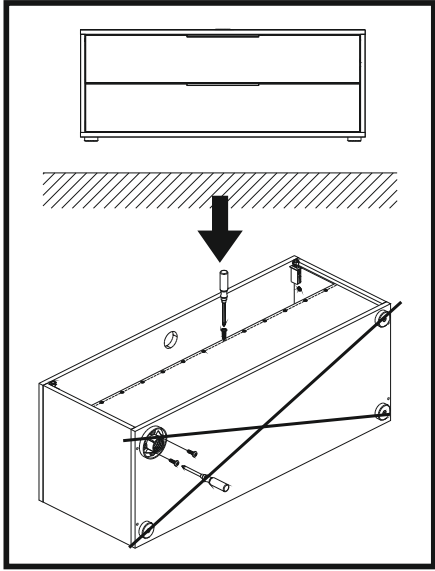
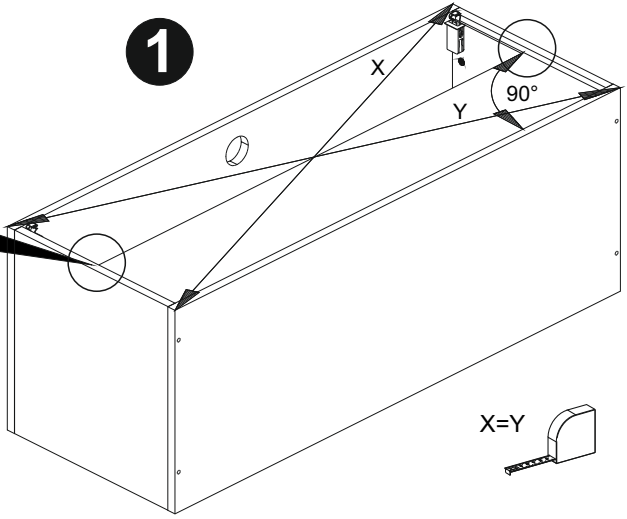

2

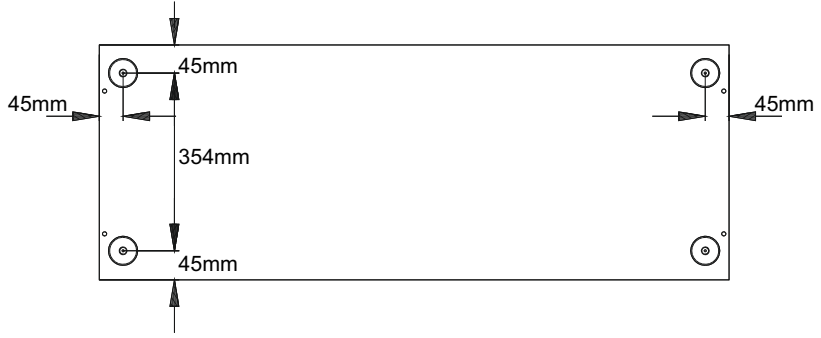
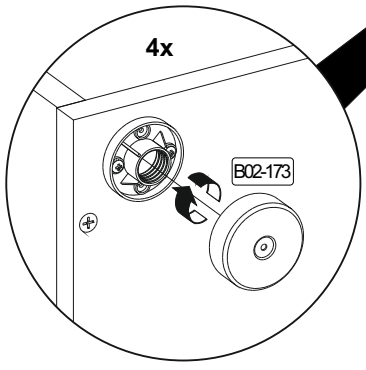
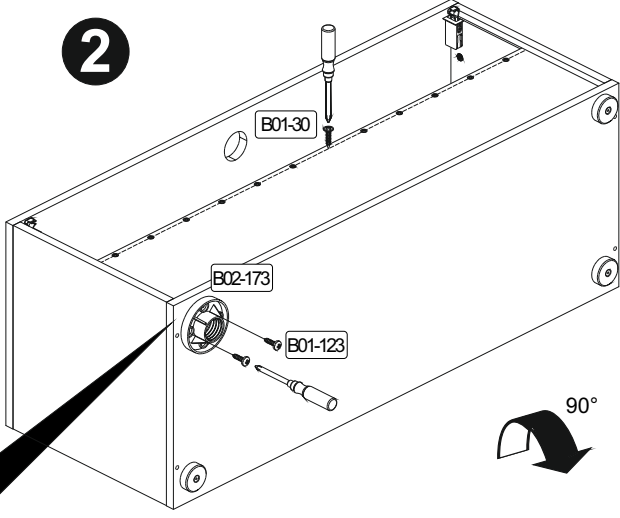

7

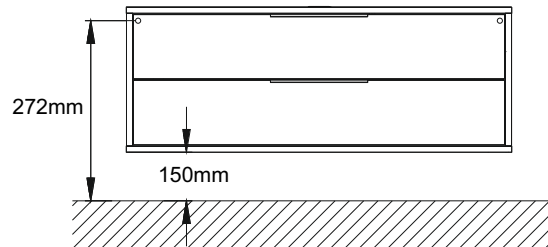
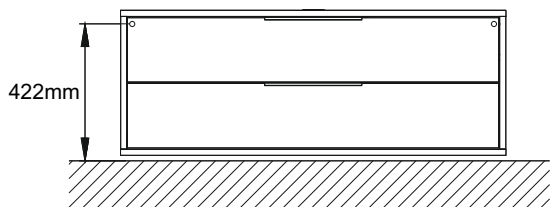
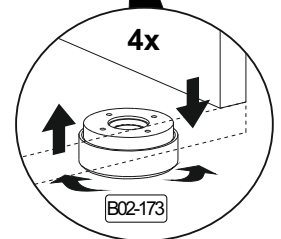
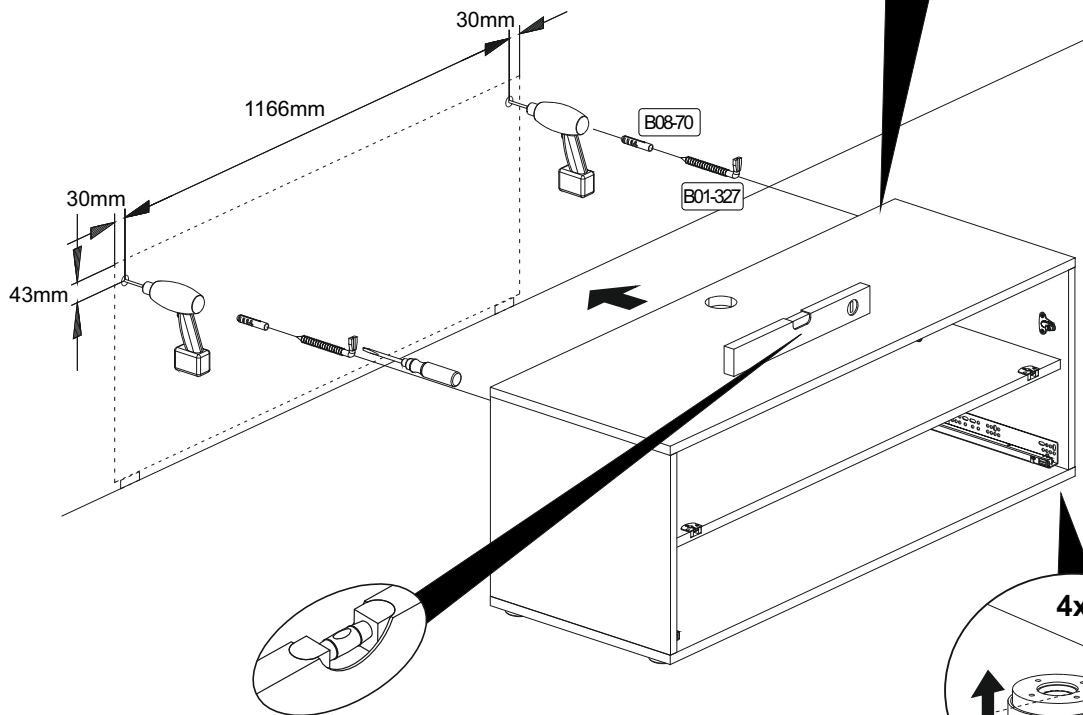
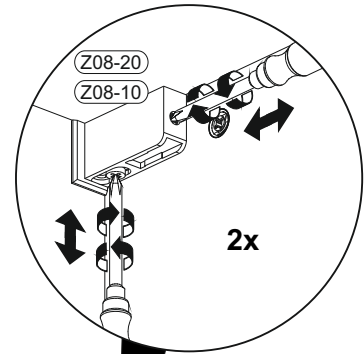
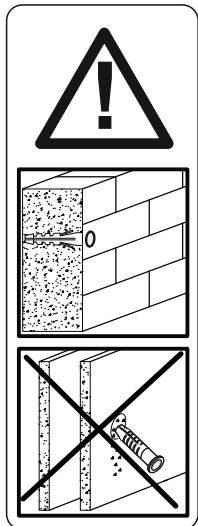
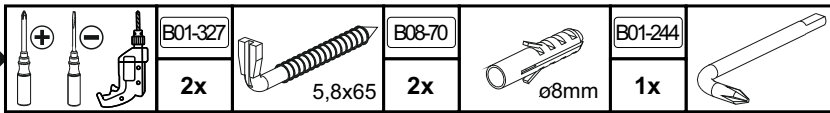

<b>Achtung • Attention • Attenzione • Opgelet • Uwaga • Pozor • Figyelem • Atenție • Dikkat • Внимание</b>	
<b>(D)</b>	Wandbefestigung dient als Kippschutz - unbedingt anbringen! Bei einigen Wandtypen kann ein Spezialdübel erforderlich sein!
<b>(GB)</b>	The wall fastening serves to prevent tipping - be absolutely sure to mount it! For certain wall types, a special wall plug may be necessary!
<b>(FR)</b>	La fixation murale sert de protection contre le basculement – à installer impérativement ! Pour certains types de murs il faut des chevilles spéciales !
<b>(TR)</b>	Duvardaki sabitleme, devrilmeye karşı bir emniyet tedbiridir ve mutlaka monte edilmelidir! Bazı duvar tiplerinde bunun için özel bir dübel gerekli olabilir!
<b>(IT)</b>	Il fissaggio alla parete serve da protezione anti-ribaltamento – attaccarla assolutamente! Per alcune strutture di parete può essere necessario un tassello speciale!
<b>(NL)</b>	Bevestiging aan de muur dient als kantelbescherming – zeker en vast bevestigen! Bij enkele muurtypes is een speciale plug misschien vereist!
<b>(RU)</b>	Обязательно установите крепление на стене во избежание опрокидывания! Для некоторых типов стен может потребоваться специальный дюбель!
<b>(CZ)</b>	Montáž na stěnu slouží jako ochrana proti převrhnutí – bezpodmínečně umístěte! U některých typů stěn může být zapotřebí speciální hmoždinka!
<b>(HU)</b>	A terméket a falhoz kel rögzíteni, különben az felborulhat! Egyes faltípusoknál speciális tiplit kell használni!
<b>(RO)</b>	Sistemul de fixare la perete servește ca protecție la răsturnare - de montat obligatoriu! Pentru unele tipuri de pereți este posibil să fie necesar un diblu special!
<b>(SK)</b>	Upevnenie na stenu slúži ako ochrana proti prevráteniu – bezpodmienečne použite! Pre niektoré druhy stien môže byť potrebná špeciálna hmoždinka!
<b>(PL)</b>	Mocowanie do ściany jest jednocześnie zabezpieczeniem przed przewróceniem – koniecznie zamontować! Do niektórych rodzajów ścian konieczne zastosować specjalne kołki mocujące.



8

	B05-20		B05-199	
	4x	ø20mm	1x	

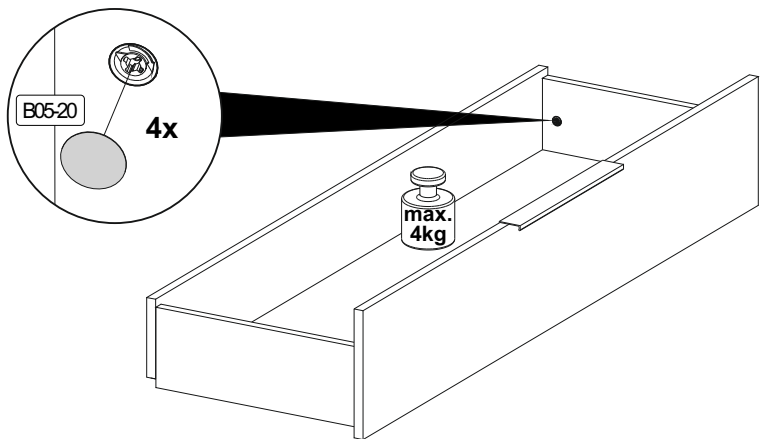
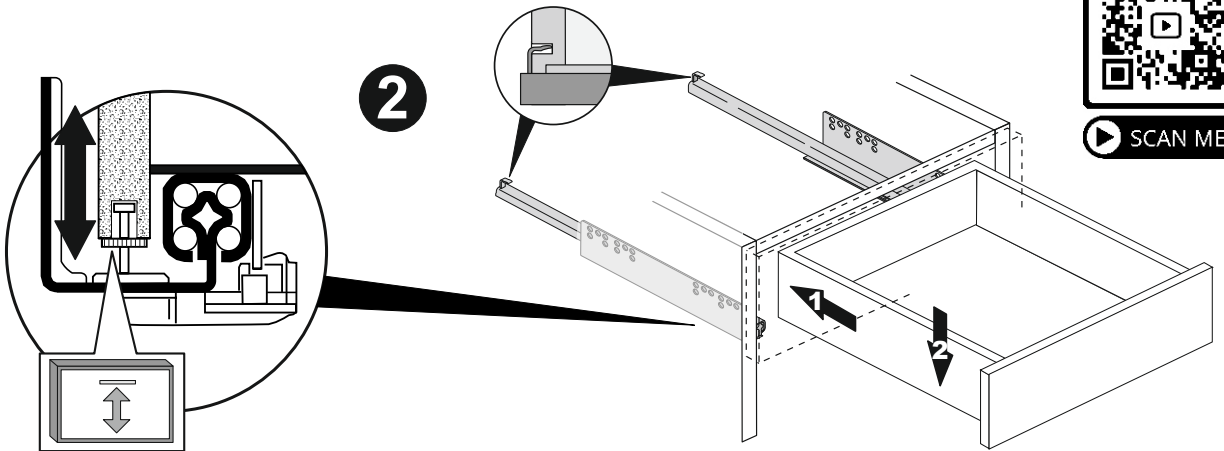
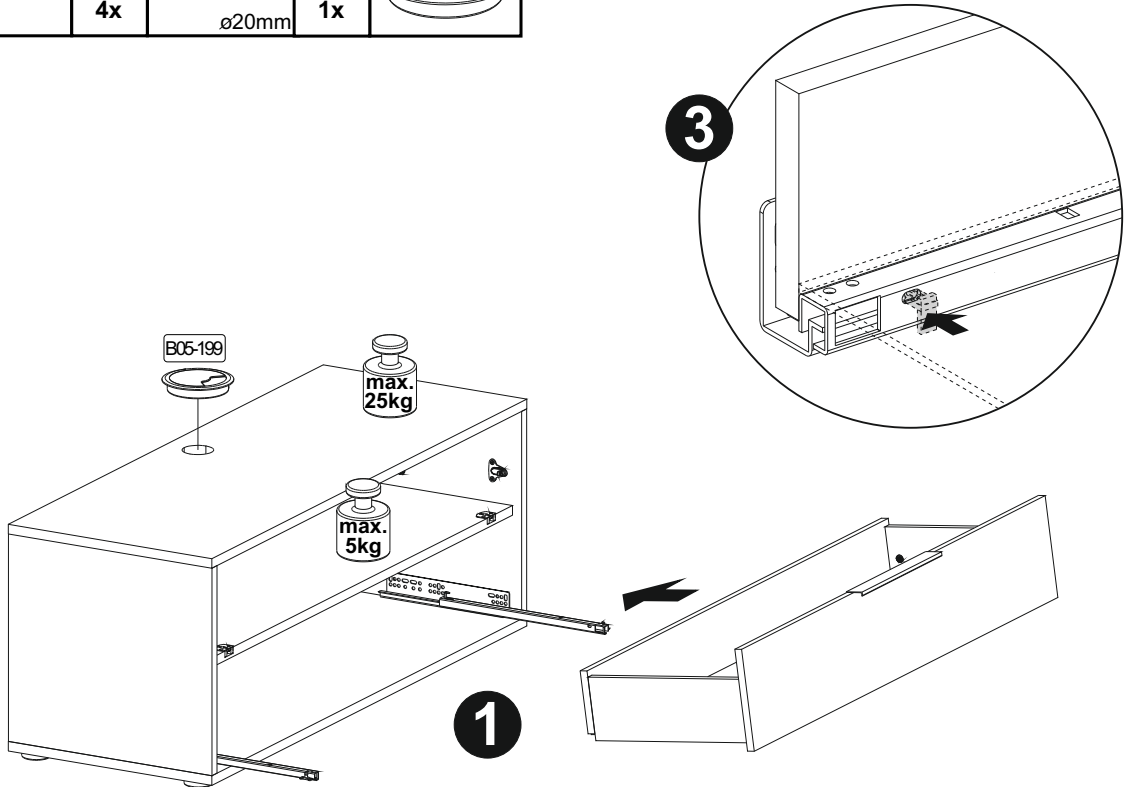

**9**

	B03-235		B01-65		B01-80		B03-225		B06-423sg	
	2x		6x	3,0x13	2x	3,5x13	1x		1x	300x15x22
									B01-200	
									2x	6,3x13

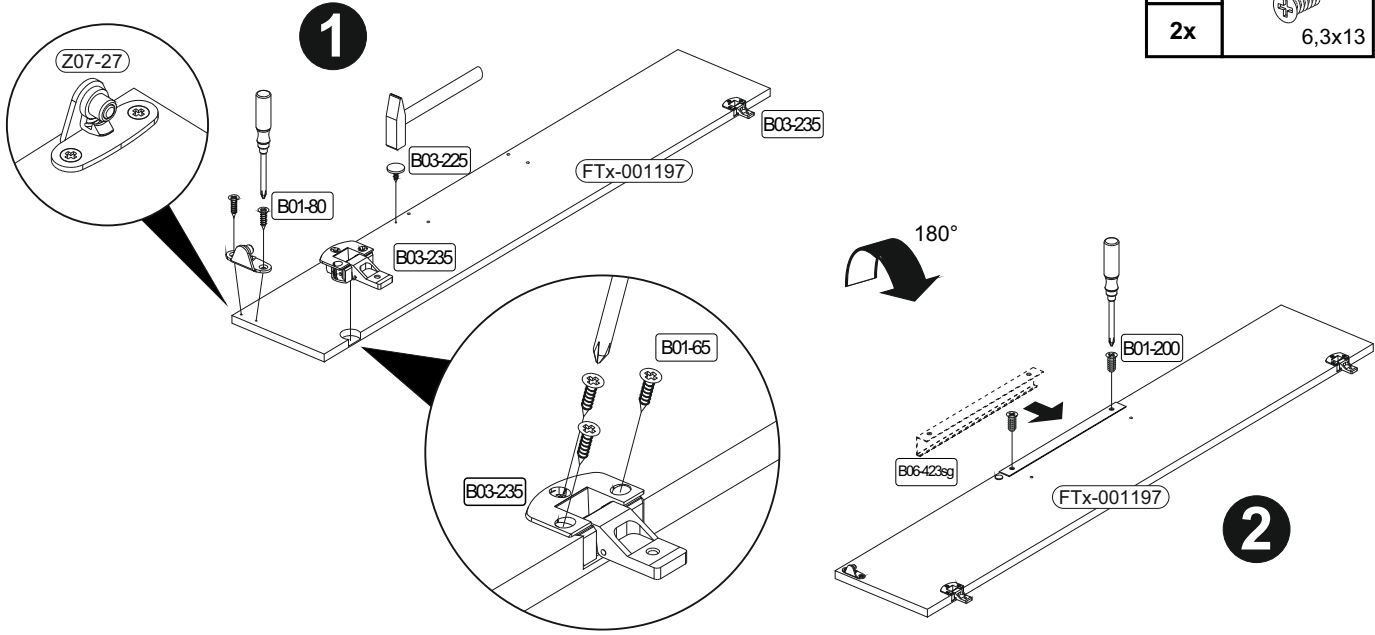

**10**

		B03-235		B01-65	
		2x		6x	3,0x13

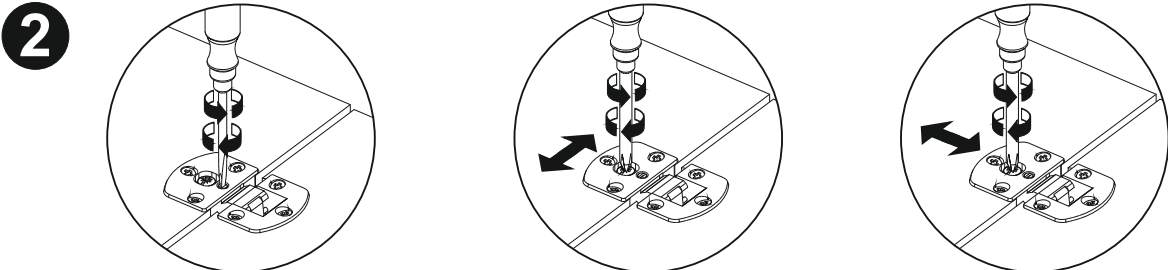
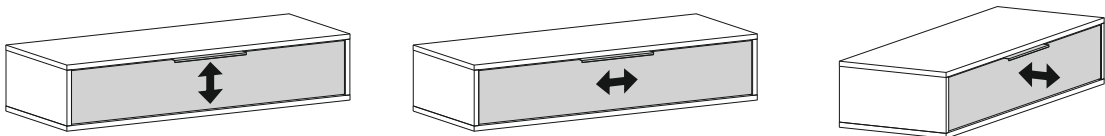
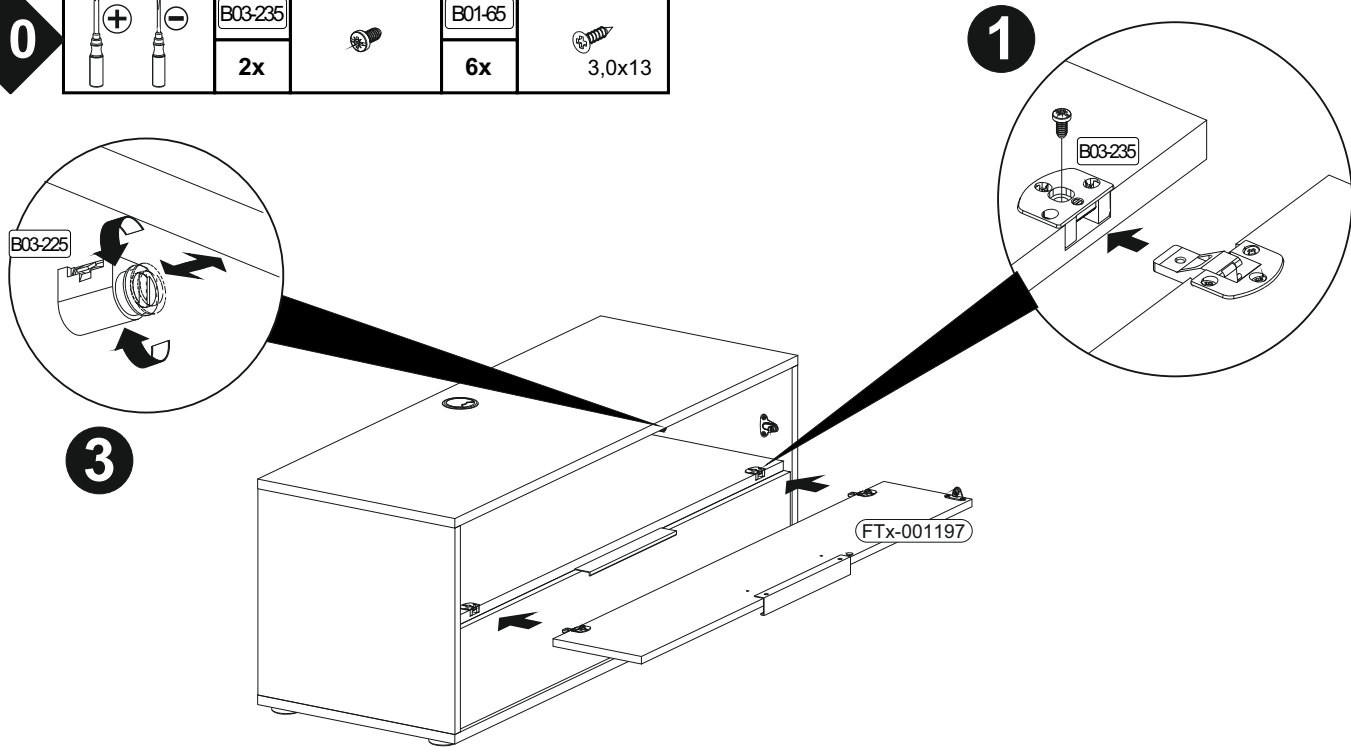

11

	B01-244	
	1x	

